

SP - WALL MIRROR WITH WHITE FRAME IN ALUMINIUM

SP 301 is the model of the **SP mirror** range, an amazing collection of mirrors of **authentic design**, where the shape, playing with transparencies and perspectives, acquires relevance and thickness in combination with an advanced technology, in order to be inserted in a functional and flexible way in real and liveable spaces.

A line that comes from a **creative experience** at the service of real people, objects designed for living environments and making the most of this time. Ideal for commercial spaces, beauty salons, makeup schools and for an high functional bathroom at home.

Handcrafted in Italy.



The ideal light reception on the face is guaranteed by the 5° splaying of the frame. Detail of the frontal, metal chromed light actuator.

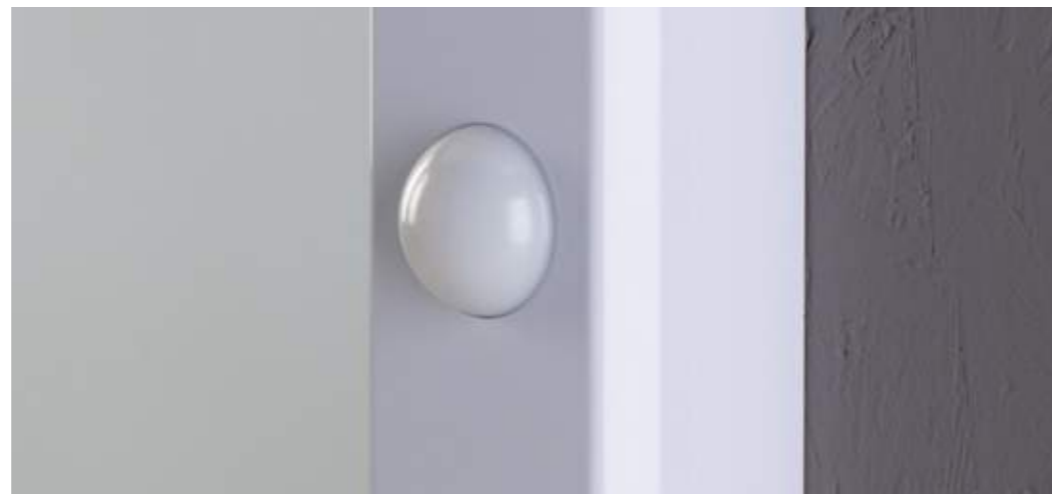

Spherical opal lenses are inserted with millimetre precision in the shaped notches on the frame.





I-light lighting professional system as a standard

SP301 is a wall mirror with I-light diffused illumination adjustable in intensity. 5° splayed frame in white painted aluminium, 5 cm (1,96 inches) thickness. The I-light technology created by Cantoni yields an 180° light around the face and remove every shadow area. The mirror has not lamps, but special lenses reflecting a led colour mixing at 4200° Kelvin.

We recommend this make-up mirror for beauty salons, perfumeries. Ideal as bathroom mirror for who desires the perfect light for his/her own beauty and facial care.

- ◆ Frame in **white aluminium**
- ◆ Lighting system with 12 *I-light* lenses
- ◆ Dimensions: mm 800x1200x55
- ◆ **Customizable** with company logo or name/text
- ◆ Handcraft in Italy
- ◆ 110V-240V compatibile



Technical sheet SP301.B

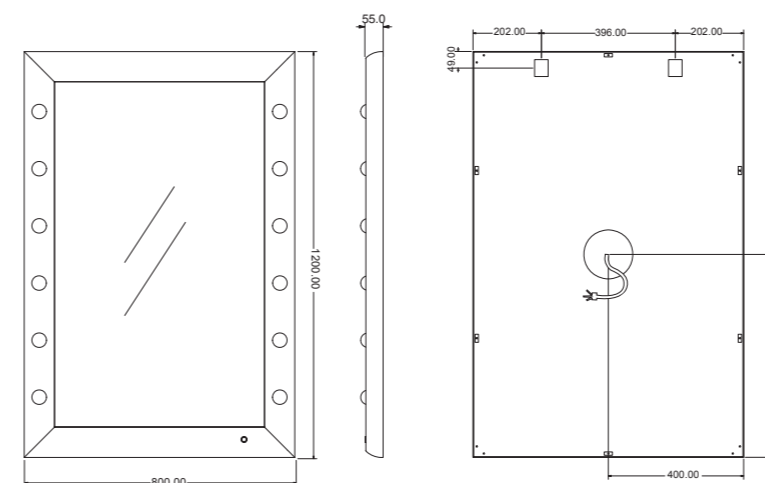

All products by Cantoni are made in Italy with carefully selected materials.
Each product is the result of a careful study to ensure the best balance between aesthetics and technology.
The authenticity of each piece by Cantoni is ensured by our trademark.

We are always available to respond to every request and question about products.
Our technical department is then available for custom projects

PLEASE NOTE:
Cantoni reserves the right to modify at any time the items in the catalogue for technical or commercial purposes.
Shipments are made from our offices in San Marino



CANTONI TRADING SRL

Headquarters

Via Guardia di Rocca 10 - 47899 Galazzano - Rep. San Marino

Registered Office e Showroom

Strada degli Angariari 25 - 47891 Rovereta - Rep. San Marino

Tel. (+378) 0549 977527 - Fax (+378) 0549 876501

sales@cantonionline.com

www.cantonionline.com

www.cantonishop.com